

SCPHA
January 12, 2025

- 36. SCPHA Trail Non Pro W/J
- 37. SCPHA Trail 12&U W/J
- 38. SCPHA Trail 1st & 2nd Year
Green Horse W/J

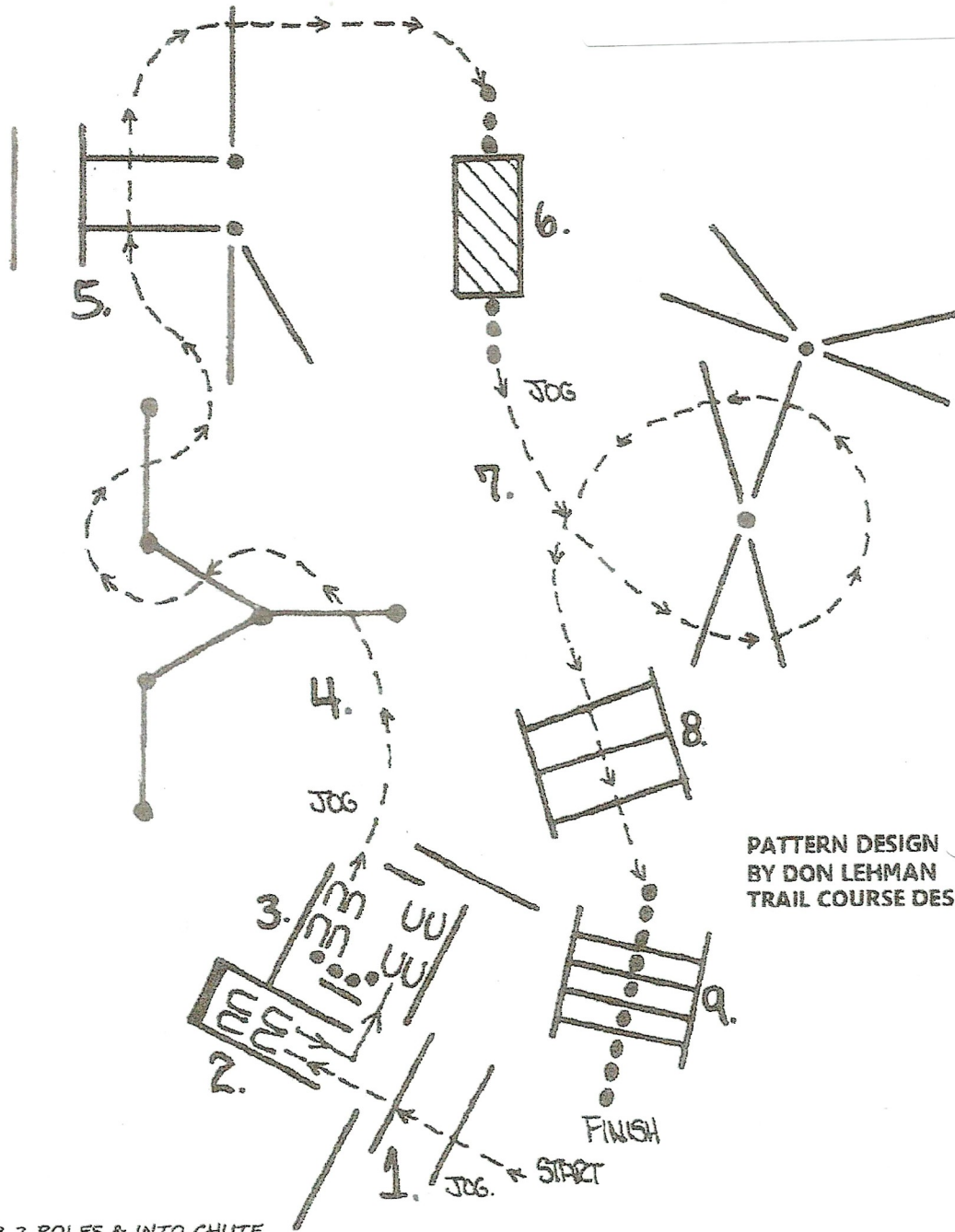

PATTERN DESIGN
BY DON LEHMAN
TRAIL COURSE DESIGNER

- 1. JOG OVER 2 POLES & INTO CHUTE
- 2. BACK THRU POLES TO GATE
- 3. WALK THRU OPEN GATE
- 4. JOG OVER 3 POLES
- 5. JOG OVER 3 POLES TO BRIDGE & STOP
- 6. WALK OVER BRIDGE
- 7. JOG OVER 4 POLES
- 8. JOG OVER 3 POLES
- 9. WALK OVER 4 POLES